

## Features

- 350 Watts Peak Pulse Power ( $t_p = 8 \times 20 \mu\text{s}$ )
- IEC 61000-4-2 (ESD): Air – 15kV, Contact – 8kV
- IEC 61000-4-4 (EFT): 40A – 5/50ns
- IEC 61000-4-5 (Surge): 24A, 8/20 $\mu\text{s}$  – Level 2(Line-Gnd) & Level 3(Line-Line)
- Low Capacitance, typ. = 3 pF
- Unidirectional Configuration
- **Lead Free/RoHS Compliant (Note 4)**
- **“Green” Device (Note 5)**

## Mechanical Data

- Case: SOD-323
- Case Material: Molded Plastic, “Green” Molding Compound, Note 5. UL Flammability Classification Rating 94V-0
- Moisture Sensitivity: Level 1 per J-STD-020D
- Terminals: Solderable per MIL-STD-202, Method 208
- Lead Free Plating (Matte Tin Finish annealed over Alloy 42 leadframe).
- Polarity: Cathode Band, See Page 2
- Marking Information: See Page 2
- Ordering Information: See Page 2
- Weight: 0.004 grams (approximate)



Top View

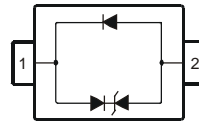

TOP VIEW

Device Schematic

## Maximum Ratings @ $T_A = 25^\circ\text{C}$ unless otherwise specified

Characteristic	Symbol	Value	Unit
Peak Pulse Power ( $t_p = 8 \times 20 \mu\text{s}$ ) (Note 7) $T_A = 25^\circ\text{C}$	$P_{pk}$	350	W

## Thermal Characteristics

Characteristic	Symbol	Value	Unit
Thermal Resistance, Junction to Ambient (Note 7) $T_A = 25^\circ\text{C}$	$R_{\theta JA}$	425	$^\circ\text{C/W}$
Operating and Storage Temperature Range	$T_J, T_{STG}$	-55 to +150	$^\circ\text{C}$

## Electrical Characteristics @ $T_A = 25^\circ\text{C}$ unless otherwise specified (Note 8)

Reverse Standoff Voltage	Breakdown Voltage $V_{BR}$ @ $I_T$		Test Current $I_T$ (mA)	Max. Reverse Leakage @ $V_{RWM}$ (Note 6) $I_R$ ( $\mu\text{A}$ )	Max. Clamping Voltage @ $I_{PP} = 1\text{A}$ (Note 3) $V_C$ (V)	Max. Clamping Voltage $V_C$ @ $I_{PP}$ (Note 3)		Typical Total Capacitance $C_T$ (Note 1) (pF)
	$V_{RWM}$ (V)	Min (V)				Max (V)	$V_C$ (V)	
3.3	4.0	—	1.0	5	7	19	20	3

- Notes:
1.  $V_R = 0\text{V}$ ,  $f = 1\text{MHz}$ .
  2.  $t_p = 8 \times 20 \mu\text{s}$ .
  3. Clamping voltage value is based on an  $8 \times 20 \mu\text{s}$  peak pulse current ( $I_{pp}$ ) waveform (see figure 1).
  4. No purposefully added lead.
  5. Diodes Inc.'s “Green” policy can be found on our website at [http://www.diodes.com/products/lead\\_free/index.php](http://www.diodes.com/products/lead_free/index.php).
  6. Short duration pulse test used to minimize self-heating effect.
  7. Device mounted on FR-4 PC board with suggested pad layout, which can be found on page 3 or on our website at <http://www.diodes.com/datasheets/ap02001.pdf>.
  8. Positive potential is applied from pin 2 to pin 1.

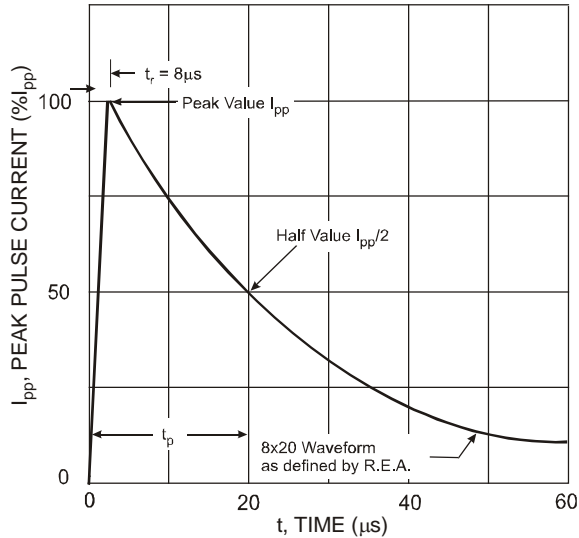

Fig. 1 Pulse Waveform

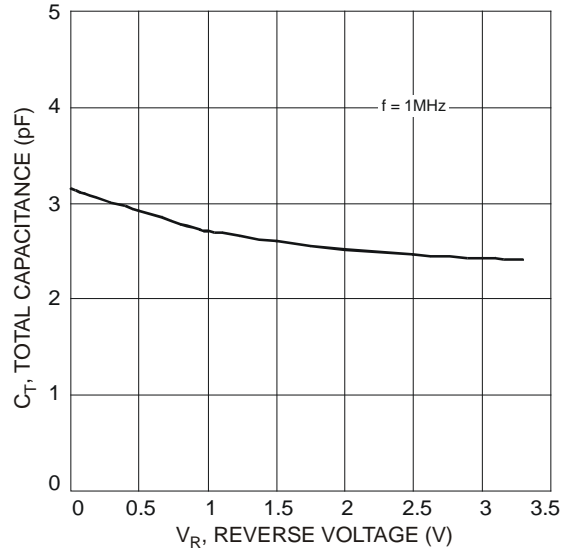

Fig. 2 Typical Total Capacitance vs. Reverse Voltage

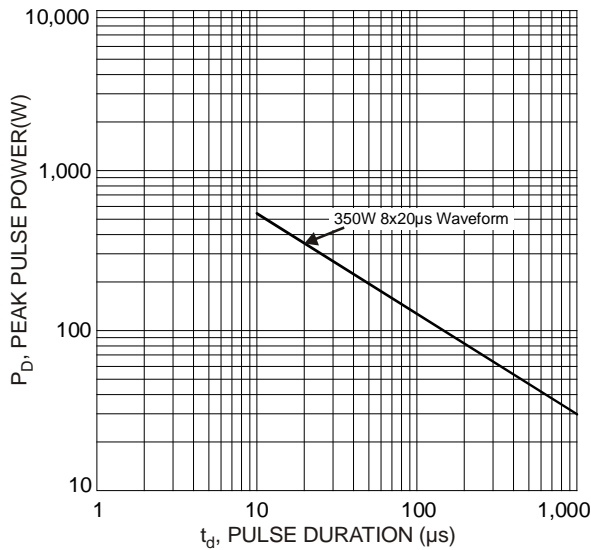

Fig. 3 Max. Peak Pulse Power vs. Power Duration

**Ordering Information** (Note 9)

Part Number	Case	Packaging
T3V3LCS3-7	SOD-323	3000/Tape & Reel

Notes: 9. For packaging details, go to our website at <http://www.diodes.com/datasheets/ap02007.pdf>.

**Marking Information**



DE = Product Type Marking Code

## Package Outline Dimensions

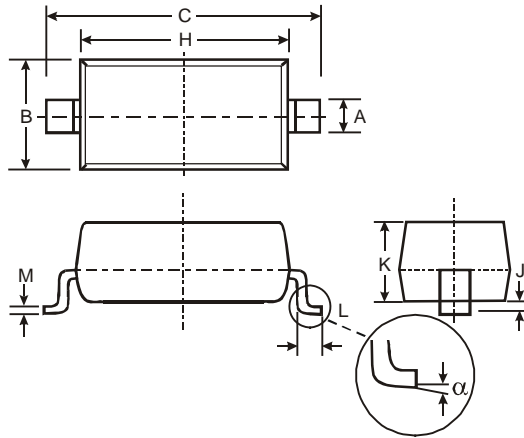

SOD-323		
Dim	Min	Max
A	0.25	0.35
B	1.20	1.40
C	2.30	2.70
H	1.60	1.80
J	0.00	0.10
K	1.0	1.1
L	0.20	0.40
M	0.10	0.15
$\alpha$	0°	8°
All Dimensions in mm		

## Suggested Pad Layout

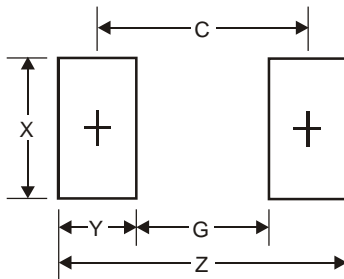

Dimensions	Value (in mm)
Z	3.75
G	1.05
X	0.65
Y	1.35
C	2.40

### IMPORTANT NOTICE

Diodes Incorporated and its subsidiaries reserve the right to make modifications, enhancements, improvements, corrections or other changes without further notice to any product herein. Diodes Incorporated does not assume any liability arising out of the application or use of any product described herein; neither does it convey any license under its patent rights, nor the rights of others. The user of products in such applications shall assume all risks of such use and will agree to hold Diodes Incorporated and all the companies whose products are represented on our website, harmless against all damages.

### LIFE SUPPORT

Diodes Incorporated products are not authorized for use as critical components in life support devices or systems without the expressed written approval of the President of Diodes Incorporated.